



Collezione - Collection: BULL VERTIGO

Articolo - Code: wc WCMBV

Articolo - Code: cassetta
cassette for monoblock CMB

Articolo - Code: batteria di scarico BB
mech. dual flush + plastic
carter

Peso - Weight: KG 35

Scarico - Flush: 6 lt

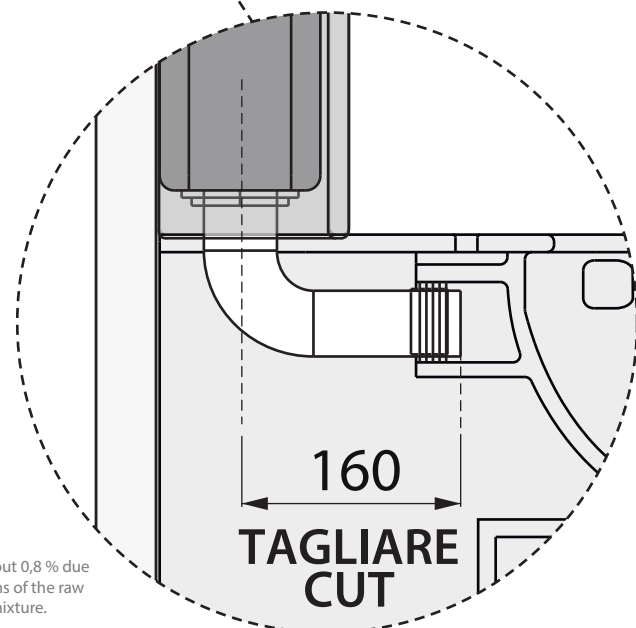
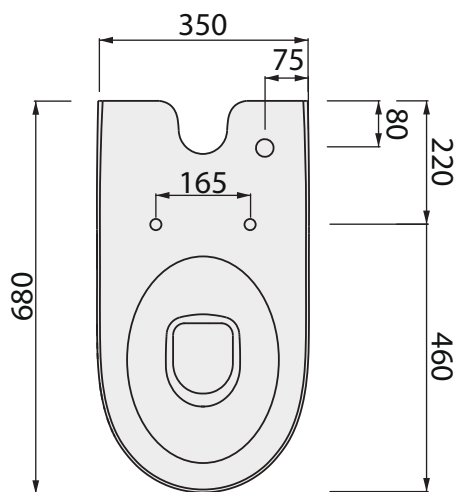
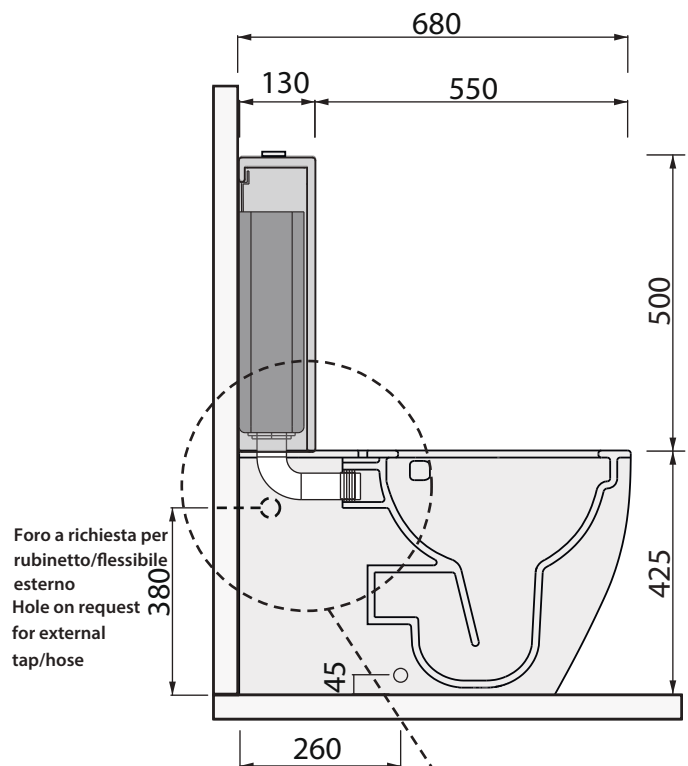
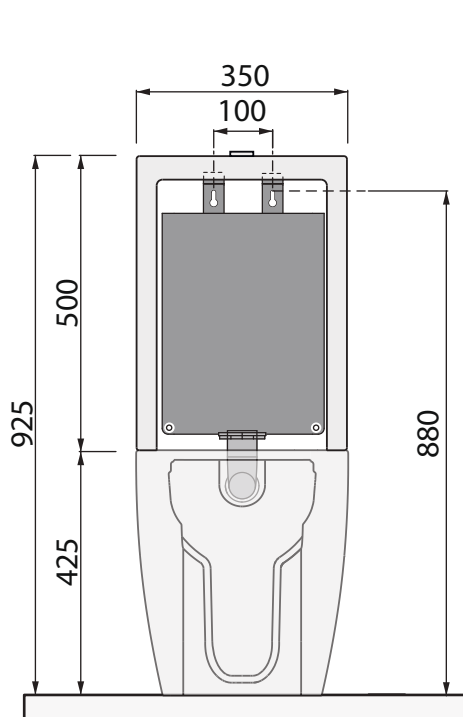

N.B.: Le misure indicate possono subire una variazione dello 0,8 % circa, dovuta ad usura degli stampi o a piccole variazioni delle caratteristiche tecniche relative alle materie prime che compongono l'impasto.

N.B.: Indicated size could have a variation of about 0,8 % due to the usure of the moulds or the small variations of the raw materials' technical characteristics used in the mixture.

SDR ceramiche srl

Località Quartaccio, snc 01034 Fabrica Di Roma (VT) tel. +39 0761 541055 - tecnico@sdr ceramiche.it - www.sdr ceramiche.it



Collezione - Collection: BULL VERTIGO

Articolo - Code: wc WCMBV

Articolo - Code: cassetta CMB
cassette for monoblock

Articolo - Code: batteria di scarico BB
mech. dual flush + plastic
carter

Peso - Weight: KG 35

Scarico - Flush: 6 lt

**installazione con presa
dell'acqua dal basso
Bottom water inlet installation**

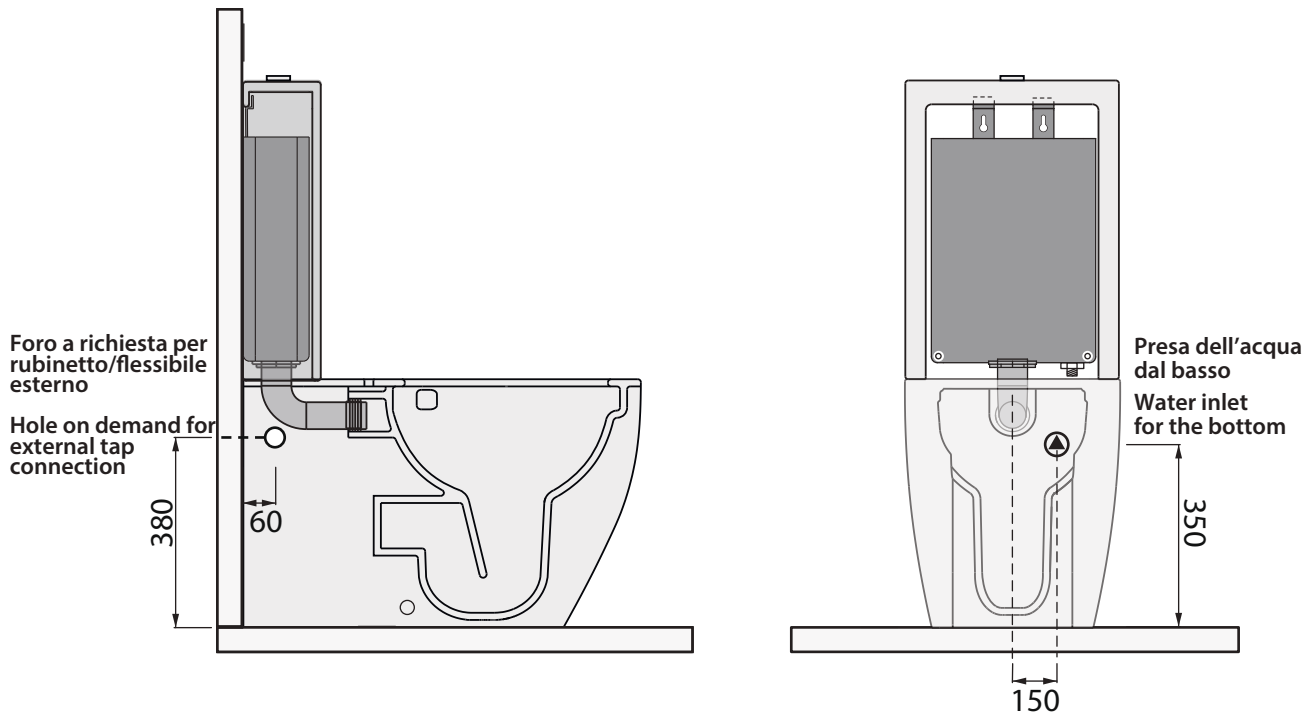

**Spazio aperto
dietro al wc
Open space
behind the WC**

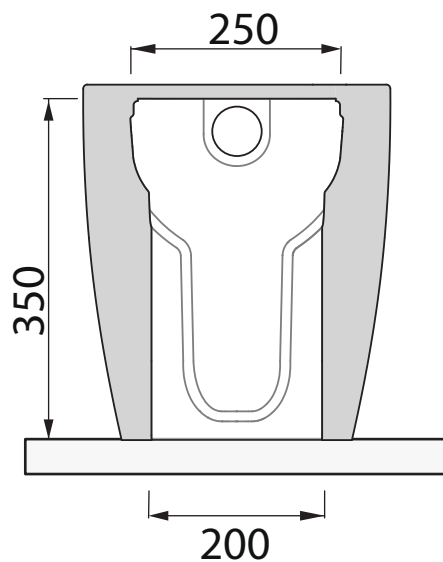



Collezione - Collection: BULL VERTIGO

Articolo - Code: wc WCMBV

Articolo - Code: cassetta CMB
cassette for monoblock

Articolo - Code: batteria di scarico BB
mech. dual flush + plastic
carter

Peso - Weigt: KG 35

Scarico - Flush: 6 lt

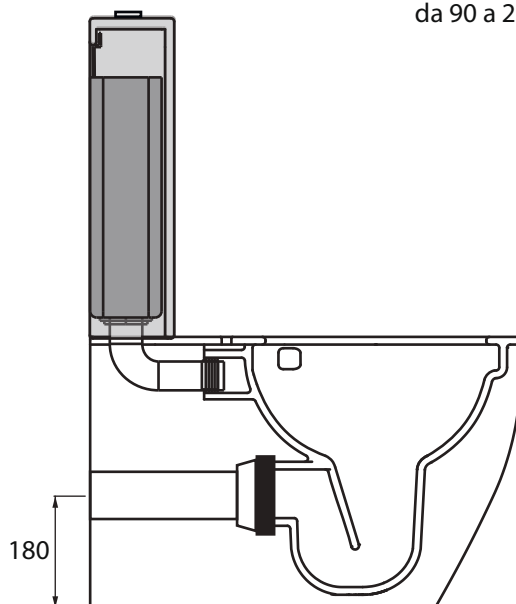
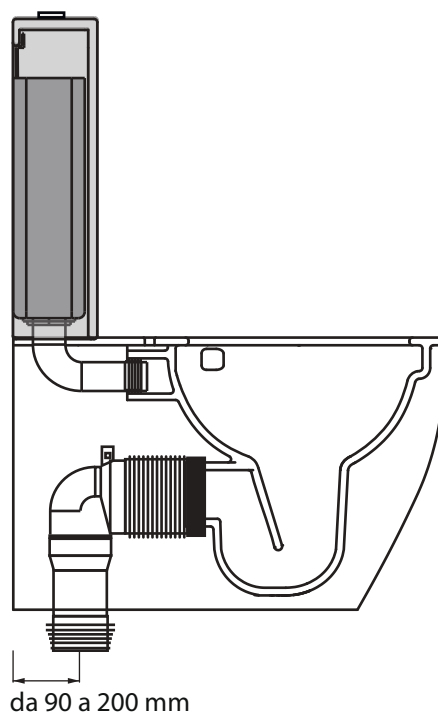
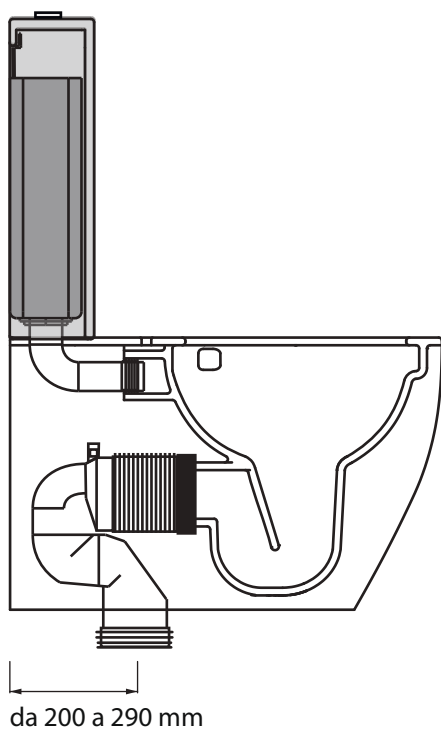



step di installazione presa acqua dal basso

Installation step

Collezione - Collection: BULL VERTIGO
Articolo - Code: wc WCMBV
Articolo - Code: cassetta cassette for monoblock CMB
Articolo - Code: batteria di scarico BB mech. dual flush + plastic carter
Peso - Weigt: KG 35
Scarico - Flush: 6 lt

